

Parts manual



From Serial Number:

C2183155

Page 07

Page 03-04

Page 12

Page 11

Page 13-19

Page 22

Page 08

Page 09-10

Page 5-6

Hydraulic scheme
Page 20-21
Hydraulic
Page 13-19
Decals Page 2



TM

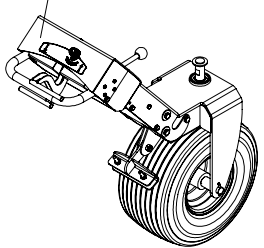
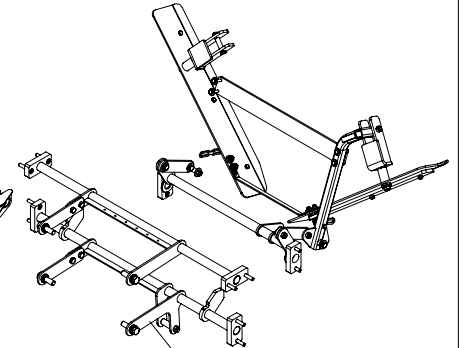
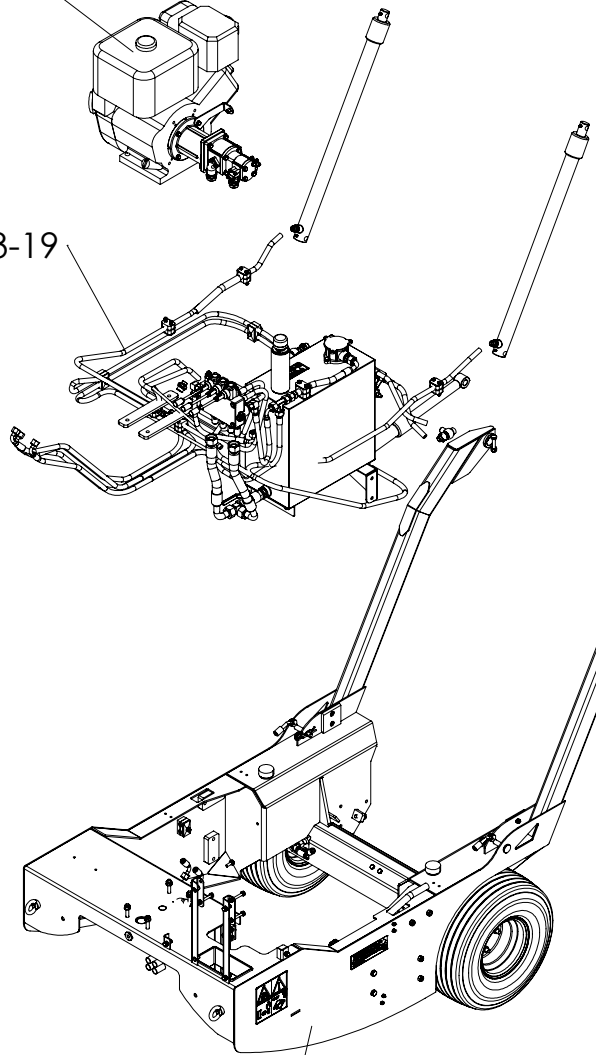
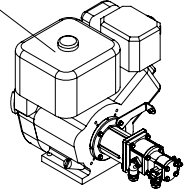
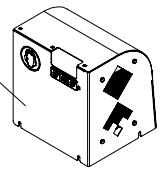
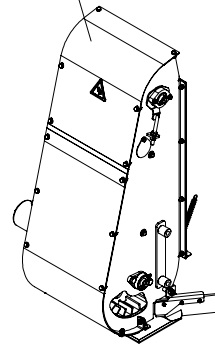
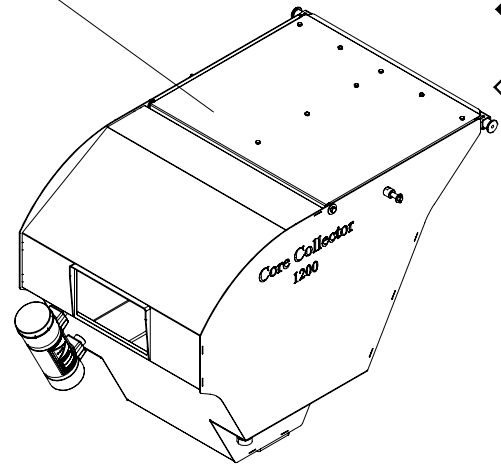

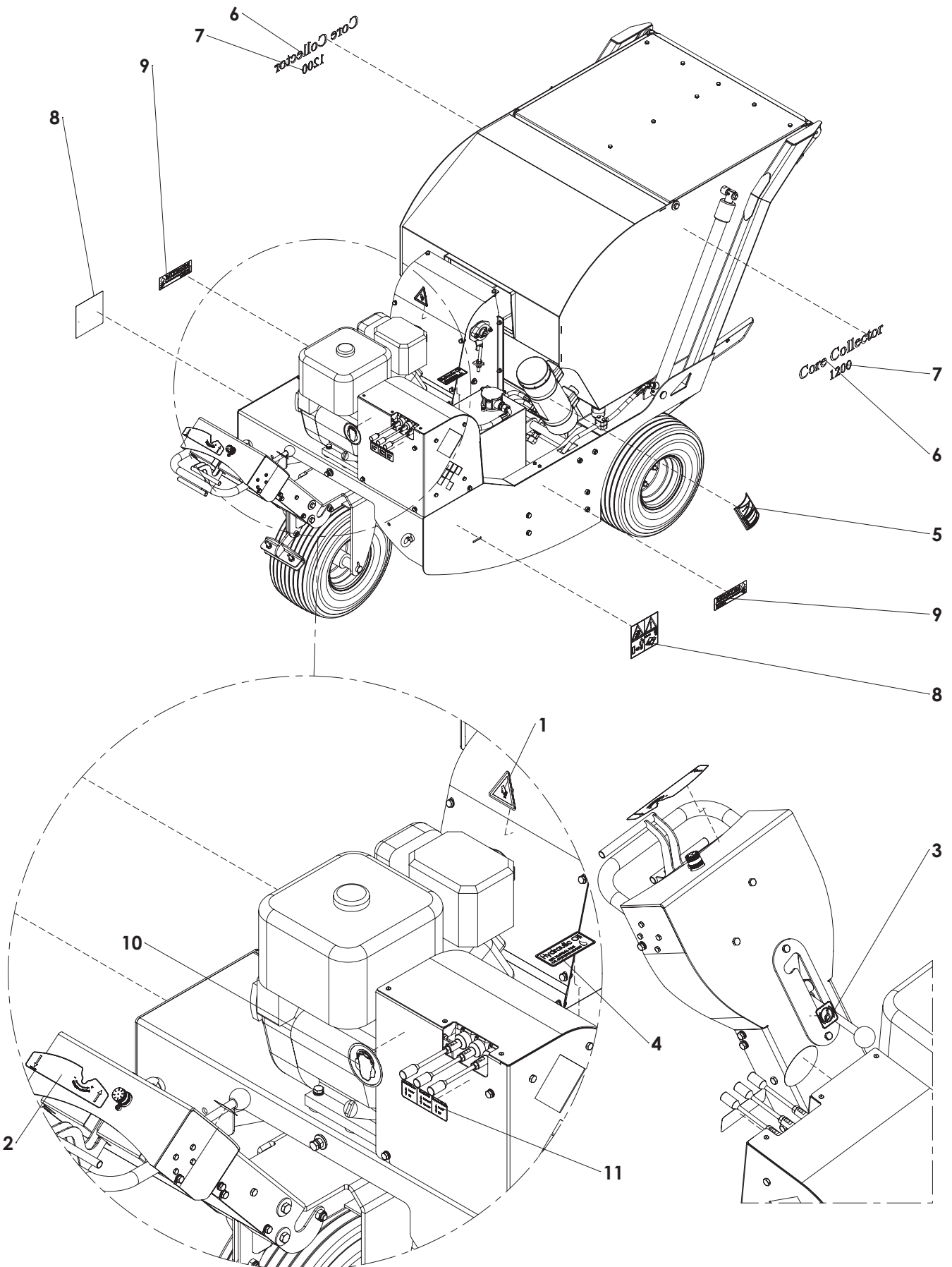

ITEM	PART NUMBER	DESCRIPTION	REMARKS	QUA
1	900.280.404	Decall cut off fingers		1
2	943.340.002	Decall driving speed		1
3	911.280.406	Decall parking brake		1
4	911.340.406	Decall oil tank		1
5	900.280.402	Safety decall manual		1
6	924.260.480	Label Core Collector		2
7	913.260.406	Decall 1200		2
8	933.280.402	Safety decall Rink Verti-Top		2
9	900.260.403	Logo Label		2
10	911.340.410	Safety decall noise		1
11	943.340.000	Decall H-levers		1

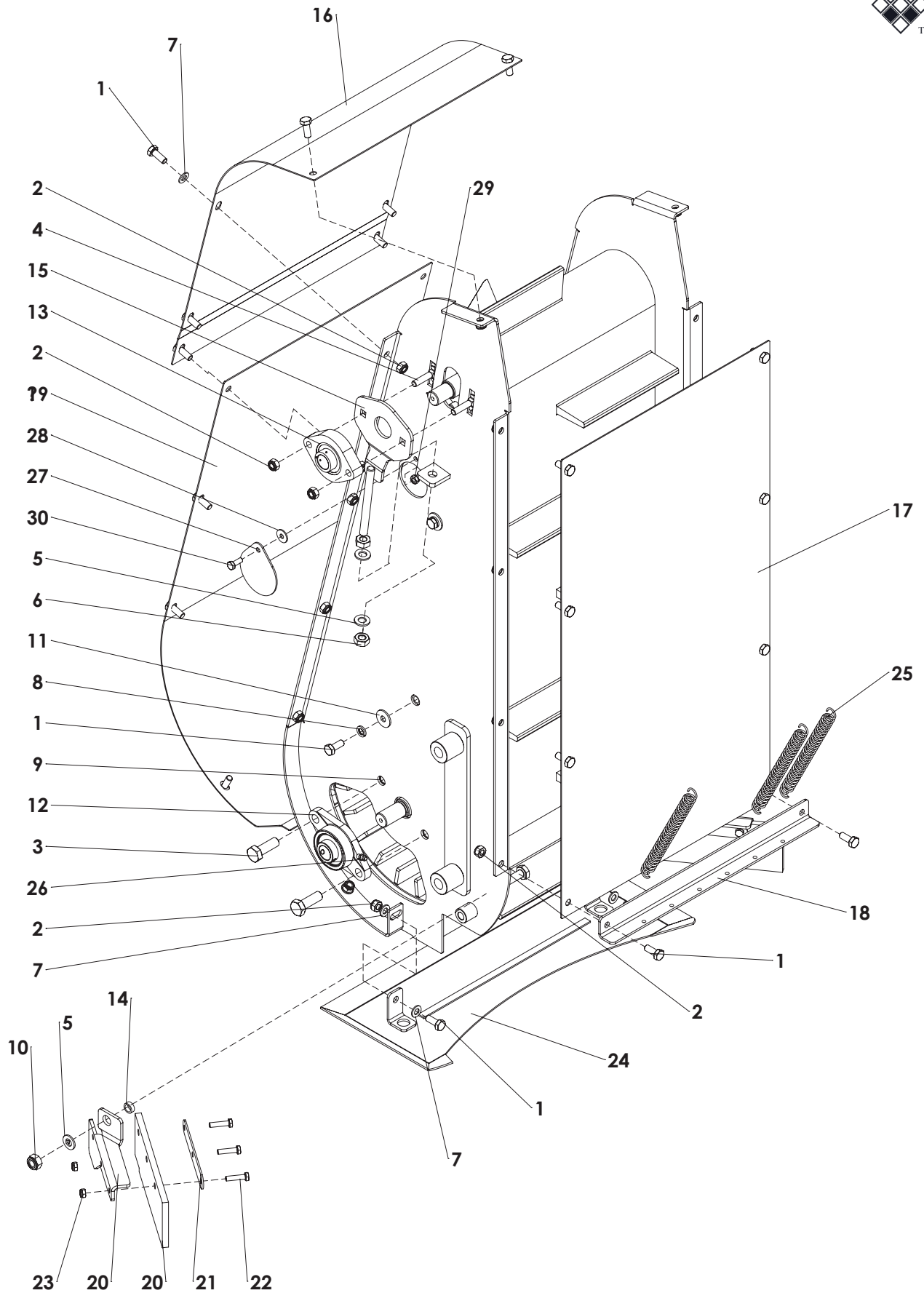

ITEM	PART NUMBER	DESCRIPTION	REMARKS	QUA
1	804.080.200	Bolt M8 x 20 - ISO 4017		26
2	830.080.080	Self Lock Nut M8 - ISO 10511		22
3	804.120.350	Bolt M12 x 35 - ISO 4017		2
4	820.080.350	MH Bolt M8 x 35 ISO 8677		2
5	864.100.030	Washer M10 - ISO 7089		3
6	826.100.100	Nut M10 - DIN 934		2
7	864.080.030	Washer M8 - ISO 7089		16
8	866.080.020	Spring Washer M8 - DIN 127		2
9	830.120.120	Self Lock Nut M12 - ISO 10511		2
10	830.100.100	Self Lock Nut M10 - ISO 10511		1
11	864.080.024	Large washer M8 - DIN 9021		2
12	742.200.330	Bearing UCFL 204		1
13	742.200.270	Bearing FLCTEY20		1
14	406.100.050	Distance bush Ø14/Ø10 L=5		1
15	470.041.960	Tensioner		1
16	468.024.402	Top cover belt		1
17	468.027.150	Belt plate		1
18	468.033.750	Spring plate		1
19	468.026.680	Rear cover plate belt		1
20	468.041.652	Pivot plate left		1
20	446.082.000	Scraper plate		1
21	468.021.402	Lock plate		1
22	804.060.250	Bolt M6 x 25 - ISO 4017		3
23	830.060.060	Self Lock Nut M6 - ISO 10511		3
24	470.024.760	Bottom blade		1
25	575.021.500	Tension Spring		3
26	880.060.100	Grease nipple M6 DIN 71412A		1
27	468.020.780	Cover		1
28	864.060.031	Large washer M6 - DIN 9021		1
29	830.060.060	Self Lock Nut M6 - ISO 10511		1
30	804.060.160	Bolt M6 x 16 - ISO 4017		1

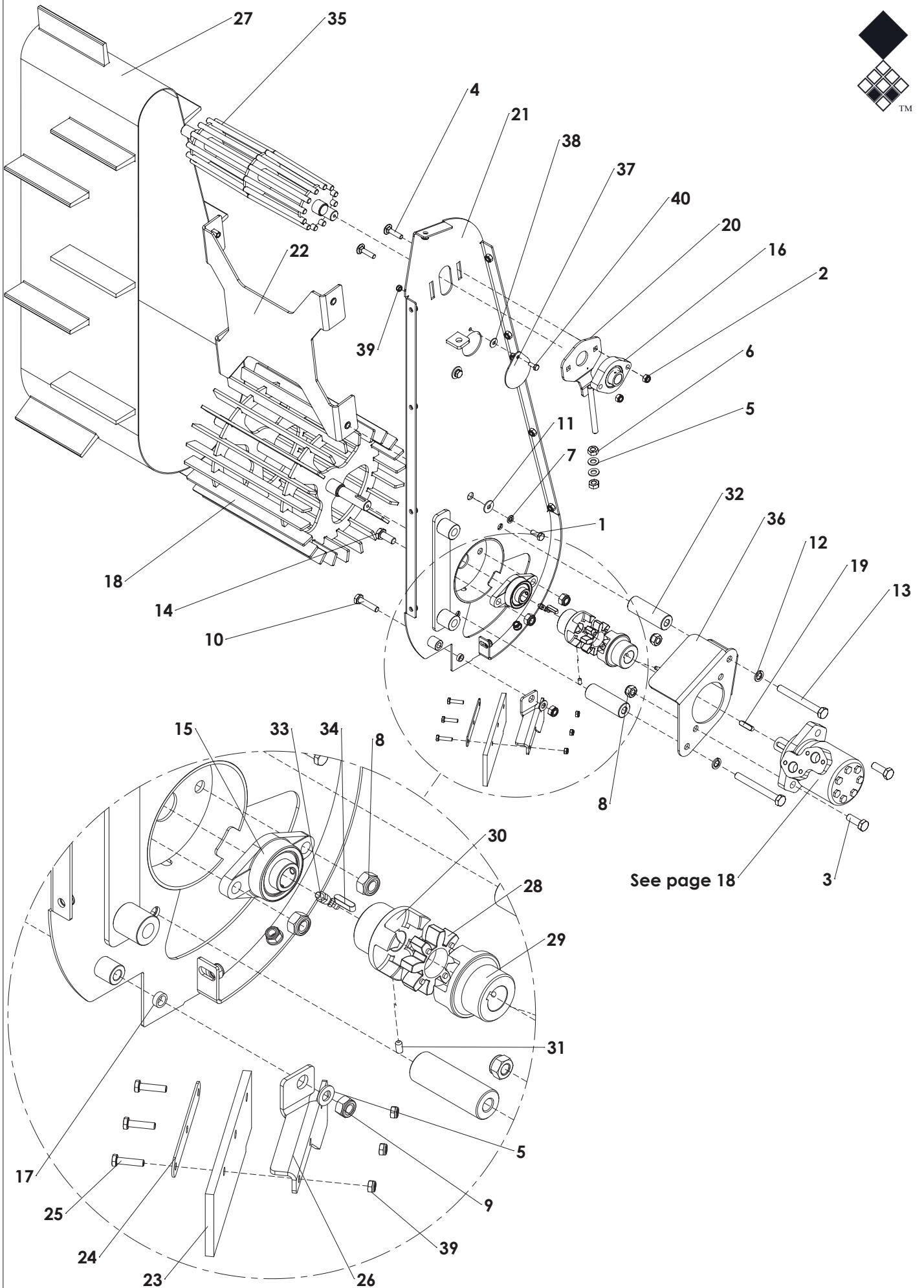

ITEM	PART NUMBER	DESCRIPTION	REMARKS	QUA
1	804.080.200	Bolt M8 x 20 - ISO 4017		2
2	830.080.080	Self Lock Nut M8 - ISO 10511		2
3	804.120.350	Bolt M12 x 35 - ISO 4017		2
4	820.080.350	MH Bolt M8 x 35 ISO 8677		2
5	864.100.030	Washer M10 - ISO 7089		2
6	826.100.100	Nut M10 - DIN 934		2
7	866.080.020	Spring Washer M8 - DIN 127		2
8	830.120.120	Self Lock Nut M12 - ISO 10511		4
9	830.100.100	Self Lock Nut M10 - ISO 10511		1
10	802.100.450	Bolt M10 x 45 - ISO 4014		1
11	864.080.024	Large washer M8 - DIN 9021		2
12	866.120.020	Spring Washer M12 - DIN 127		2
13	802.121.100	Bolt M12 x 110 - ISO 4014		2
14	804.120.300	Bolt M12 x 30 - ISO 4017		2
15	742.200.330	Bearing UCFL 204		1
16	742.200.270	Bearing FLCTEY20		1
17	406.100.050	Distance bush Ø14/Ø10 L=5		1
18	488.272.036	Driver roller		1
19	884.080.320	Key 8x7x32 - DIN 6885		1
20	470.041.960	Tensioner		1
21	470.039.104	Side plate right		1
22	470.043.170	Middle plate		1
23	446.082.000	Scraper plate		1
24	468.021.402	Lock plate		1
25	804.060.250	Bolt M6 x 25 - ISO 4017		3
26	468.041.650	Pivot plate right		1
27	492.026.950	Conveyer belt L=695		1
28	665.650.200	Coupling Rubber EGE-2-RP 92° Shore		1
29	665.250.520	Coupling half A2825 Cast Iron		1
30	665.200.520	Coupling half A2820 Cast Iron		1
31	818.060.120	Set screw M6 x 12 - DIN 916		2
32	406.130.880	Distance bush Ø30/Ø12.5 L=88		2
33	880.060.104	Grease nipple M6 45deg. DIN 71412B		1
34	884.060.250	Key 6x6x25 - DIN 6885		1
35	488.099.039	Guide roller		1
36	468.042.202	Motor cover		1
37	468.020.780	Cover		1
38	864.060.031	Large washer M6 - DIN 9021		1
39	830.060.060	Self Lock Nut M6 - ISO 10511		4
40	804.060.160	Bolt M6 x 16 - ISO 4017		1

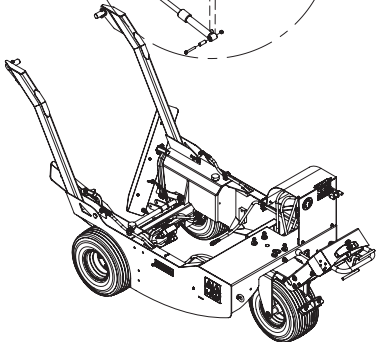
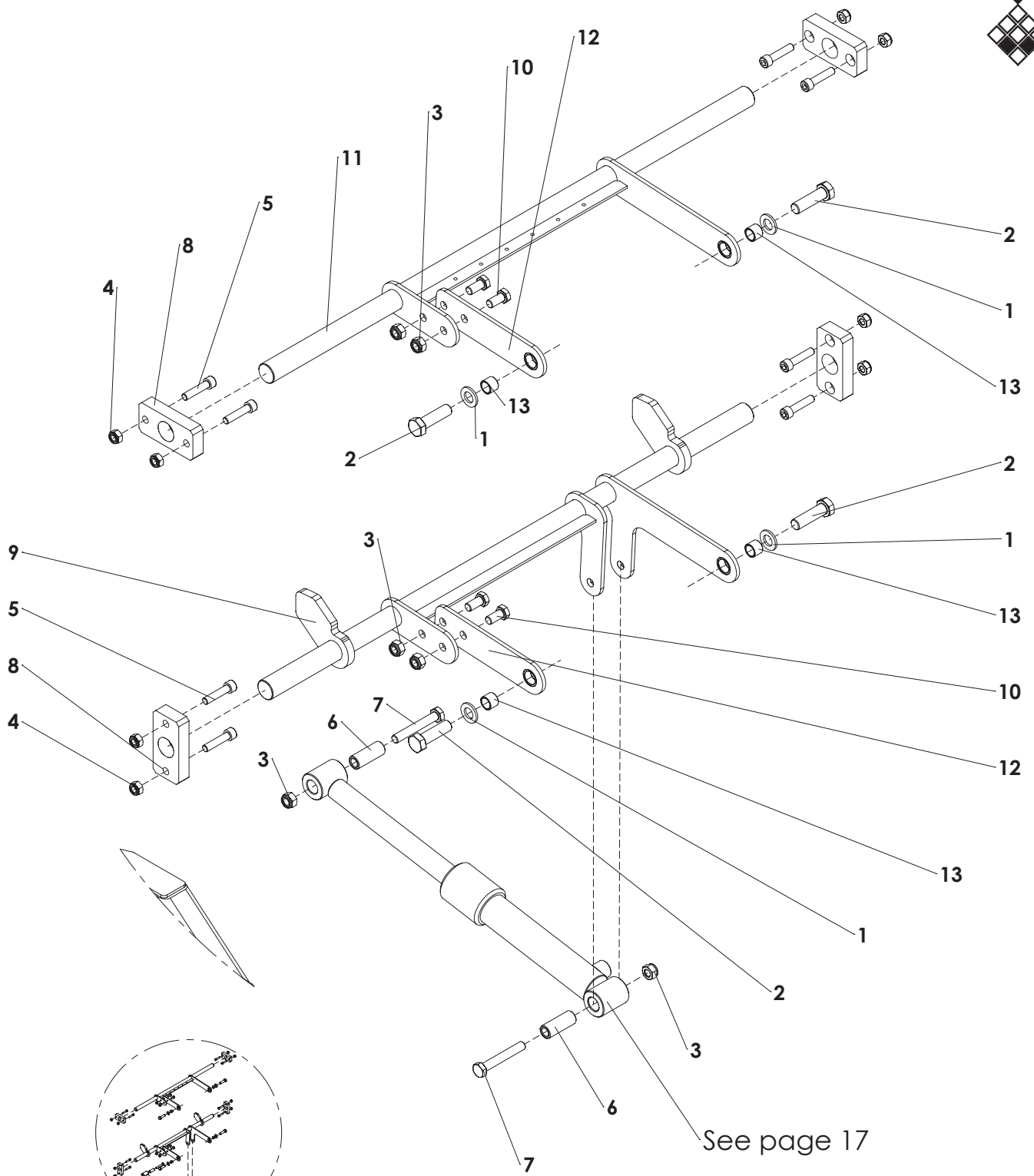

ITEM	PART NUMBER	DESCRIPTION	REMARKS	QUA
1	864.160.030	Washer M16 - ISO 7089		4
2	802.160.550	Bolt M16 x 55 - ISO 4014		4
3	830.120.120	Self Lock Nut M12 - ISO 10511		6
4	830.100.100	Self Lock Nut M10 - ISO 10511		8
5	814.100.450	Bolt M10 x 45 - DIN 912		8
6	406.130.520	Distance bush Ø20/Ø12.5 L=52		2
7	802.120.800	Bolt M12 x 80 - ISO 4014		2
8	464.201.000	Bearing block		4
9	474.308.740	Lift arm belt		1
10	804.120.250	Bolt M12 x 25 - ISO 4017		4
11	474.308.742	Top lift arm belt		1
12	474.502.300	Lock plate		2
13	406.160.152	Distance bush Ø20/Ø16.2 L=15		4

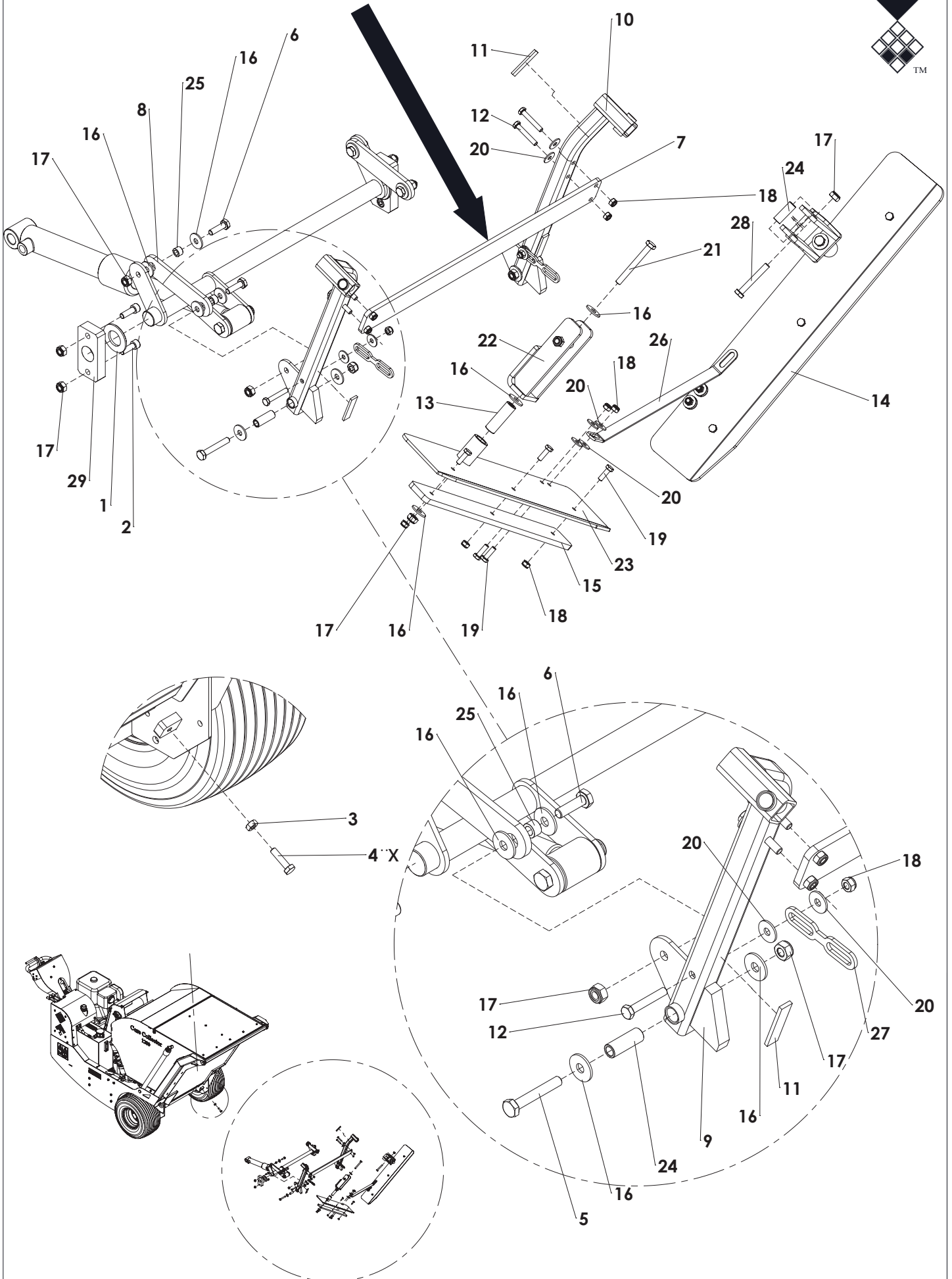

ITEM	PART NUMBER	DESCRIPTION	REMARKS	QUA
1	864.300.032	Washer M30 - ISO 7089		2
2	814.100.300	Bolt M10 x 30 - DIN 912		4
3	826.100.100	Nut M10 - DIN 934		2
4	804.100.400	Bolt M10 x 40 - ISO 4017		2
5	802.100.650	Bolt M10 x 65 - ISO 4014		2
6	804.100.350	Bolt M10 x 35 - ISO 4017		2
7	464.086.000	Strip		1
8	468.051.702	Pivot plate		2
9	462.140.474	Windrow lift arm right		1
10	462.140.473	Windrow lift arm left		1
11	446.040.600	Self adhesive rubber		4
12	802.080.500	Bolt M8 x 50 - ISO 4014		6
13	406.110.620	Distance bush Ø20/Ø10.5 L=62		2
14	470.056.500	Scraper right		1
15	464.106.000	Weight strip		2
16	864.100.031	Large washer M10 - DIN 9021		16
17	830.100.100	Self Lock Nut M10 - ISO 10511		14
18	830.080.080	Self Lock Nut M8 - ISO 10511		16
19	804.080.250	Bolt M8 x 25 - ISO 4017		10
20	864.080.024	Large washer M8 - DIN 9021		16
21	802.100.900	Bolt M10 x 90 - ISO 4014		2
22	466.080.930	Pivot bracket		2
23	470.056.502	Scraper left		1
24	406.100.420	Distance bush Ø15/Ø10 L=42		4
25	402.100.102	Bush Ø16/Ø10 L=10		4
26	846.054.600	Chain 35x20x5 11 shackles		1
27	846.041.400	Chain 35x20x5 4 shackles		2
28	802.100.700	Bolt M10 x 70 - ISO 4014		2
29	464.201.000	Bearing block		2

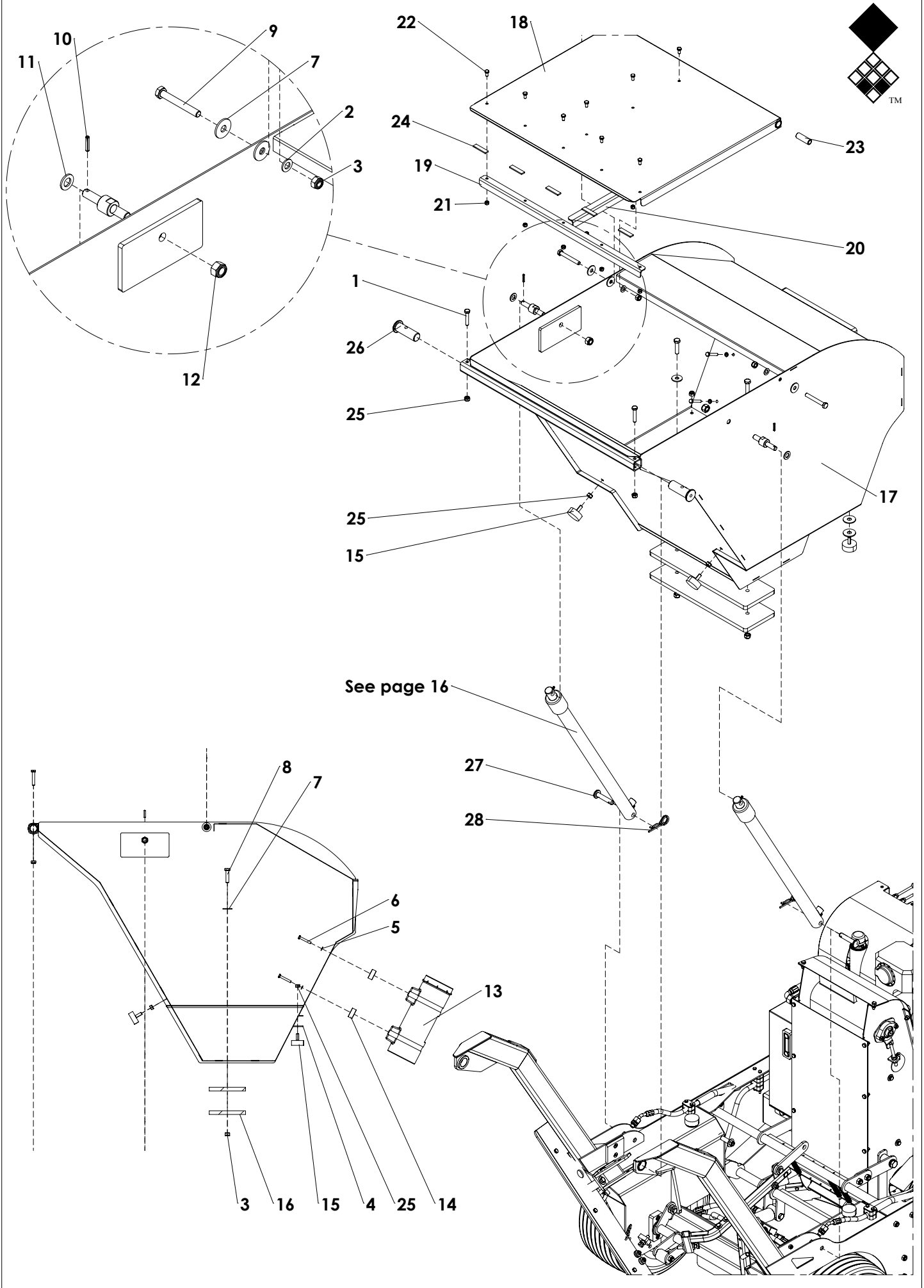

ITEM	PART NUMBER	DESCRIPTION	REMARKS	QUA
1	802.100.550	Bolt M10 x 55 - ISO 4014		2
2	864.120.030	Washer M12 - ISO 7089		2
3	830.120.120	Self Lock Nut M12 - ISO 10511		4
4	864.140.031	Large washer M14 - DIN 9021		4
5	866.080.020	Spring Washer M8 - DIN 127		2
6	804.080.500	Bolt M8 x 50 - ISO 4017		2
7	864.120.031	Large washer M12 - DIN 9021		4
8	802.120.500	Bolt M12 x 50 - ISO 4014		2
9	802.120.900	Bolt M12 x 90 - ISO 4014		2
10	878.060.300	Roll Pin 6 x 30 - ISO 8752		2
11	864.160.030	Washer M16 - ISO 7089		2
12	830.160.160	Self Lock Nut M16 - ISO 10511		2
13	444.803.100	Toolbox Complete		1
14	406.090.182	Distance bush toolbox		2
15	D208112001	Rubber stop		4
16	468.154.800	Weight strip		2
17	494.116.086	Core hopper		1
18	470.028.330	Hopper cover		1
19	468.038.000	Reinforcement angle L=800		1
20	468.035.006	Reinforcement angle L=630		1
21	830.080.080	Self Lock Nut M8 - ISO 10511		8
22	804.080.160	Bolt M8 x 16 - ISO 4017		8
23	406.130.600	Bush Ø20/Ø12.5 L=60		2
24	446.040.600	Self adhesive rubber		5
25	830.100.100	Self Lock Nut M10 - ISO 10511		6
26	418.320.980	Pivot shaft hopper		2
27	418.150.800	Pivot pin		2
28	523.051.000	R-clip Round 5, DIN 11024		2

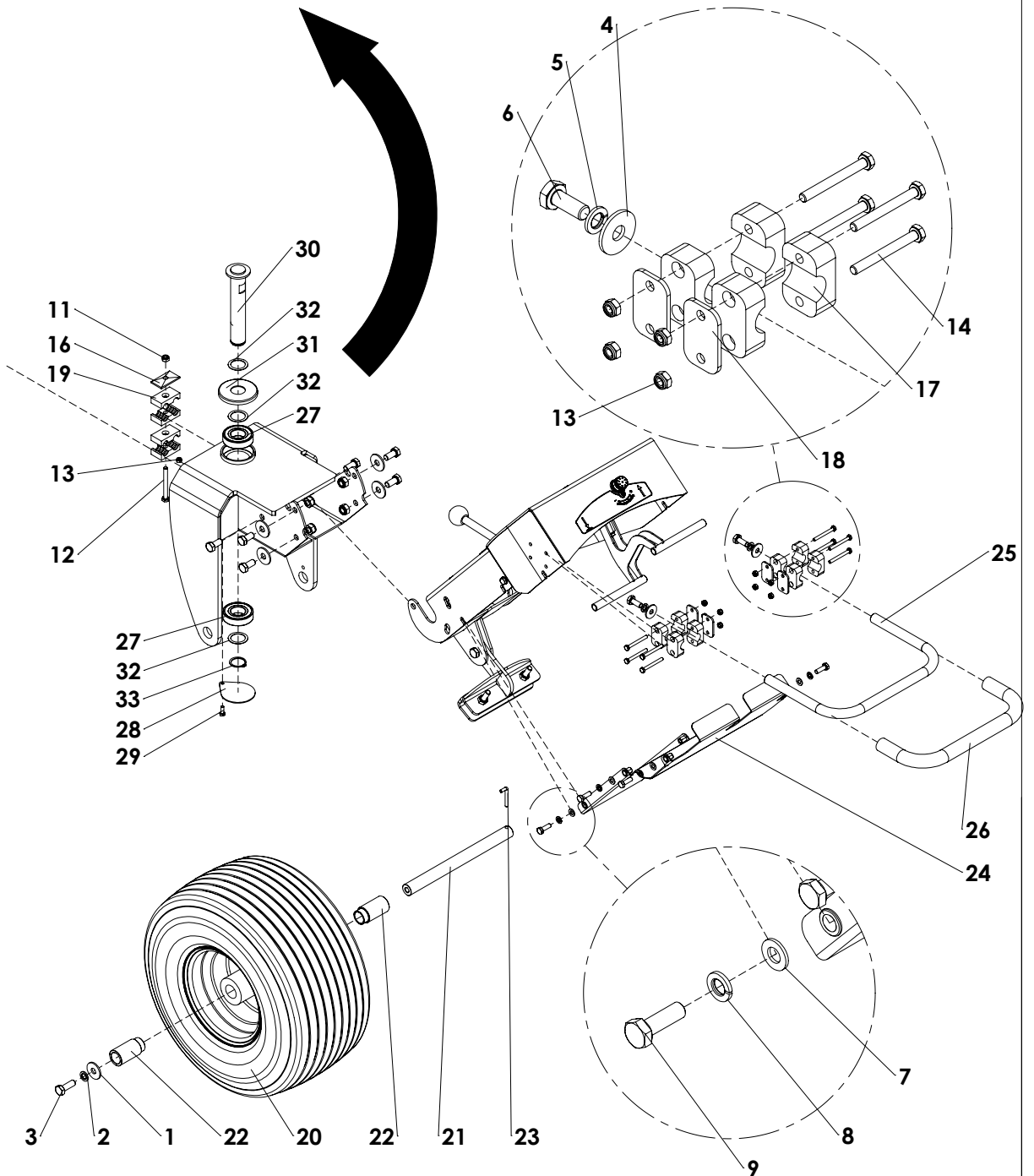
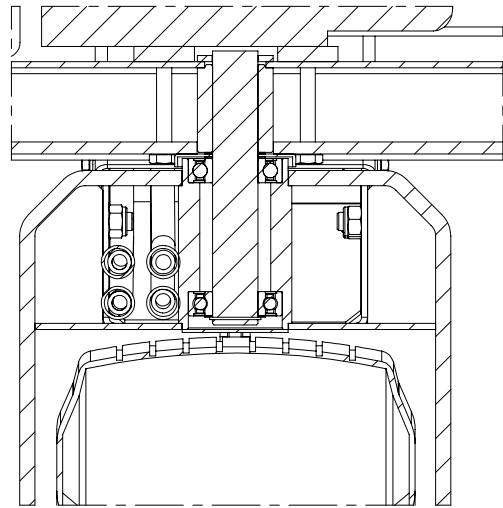
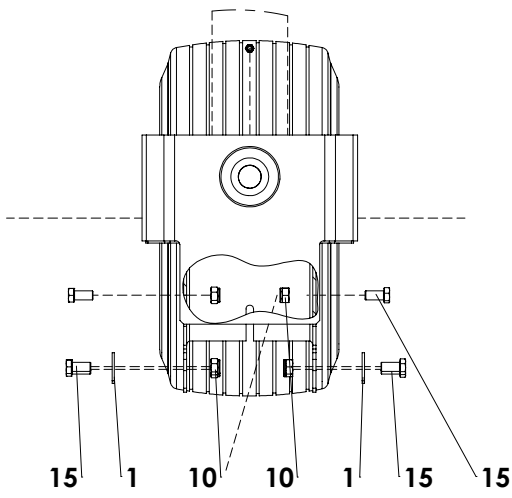
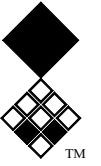

ITEM	PART NUMBER	DESCRIPTION	REMARKS	QUA
1	864.120.031	Large washer M12 - DIN 9021		5
2	866.120.020	Spring Washer M12 - DIN 127		1
3	804.120.350	Bolt M12 x 35 - ISO 4017		1
4	864.100.031	Large washer M10 - DIN 9021		2
5	866.100.020	Spring Washer M10 - DIN 127		2
6	804.100.250	Bolt M10 x 25 - ISO 4017		2
7	864.080.030	Washer M8 - ISO 7089		6
8	866.080.020	Spring Washer M8 - DIN 127		6
9	804.080.250	Bolt M8 x 25 - ISO 4017		6
10	830.120.120	Self Lock Nut M12 - ISO 10511 Class 10.9		6
11	830.080.080	Self Lock Nut M8 - ISO 10511		2
12	802.080.750	Bolt M8 x 75 - ISO 4014		2
13	830.060.060	Self Lock Nut M6 - ISO 10511		9
14	802.060.550	Bolt M6 x 55 - ISO 4014		8
15	804.120.250	Bolt M12 x 25 - ISO 4017		6
16	547.300.510	Cover plate hose clamp 2x15 - 2x18		2
17	547.200.302	Pipe clamp single Ø20 Gr3		8
18	549.300.480	Deck plate Gr3		4
19	547.150.150	Hose clamp double 15mm		8
20	511.542.236	Wheel Complete		1
21	416.252.940	Wheel Shaft		1
22	404.250.700	Distance Bush Wheel		2
23	424.060.480	Lock Pin		1
24	456.025.500	Cover		1
25	472.206.730	Bar		1
26	458.204.920	Rubber sleeve		1
27	713.300.160	Bearing DIN 6206 2RS		2
28	456.009.007	Bush cover		1
29	804.060.160	Bolt M6 x 16 - ISO 4017		1
30	474.301.834	Steering pin		1
31	729.300.800	Bearing cover		1
32	868.040.100	Shim Ø30xØ40x1.0 DIN988		3
33	870.030.160	Circlip d=30 - DIN 471		1

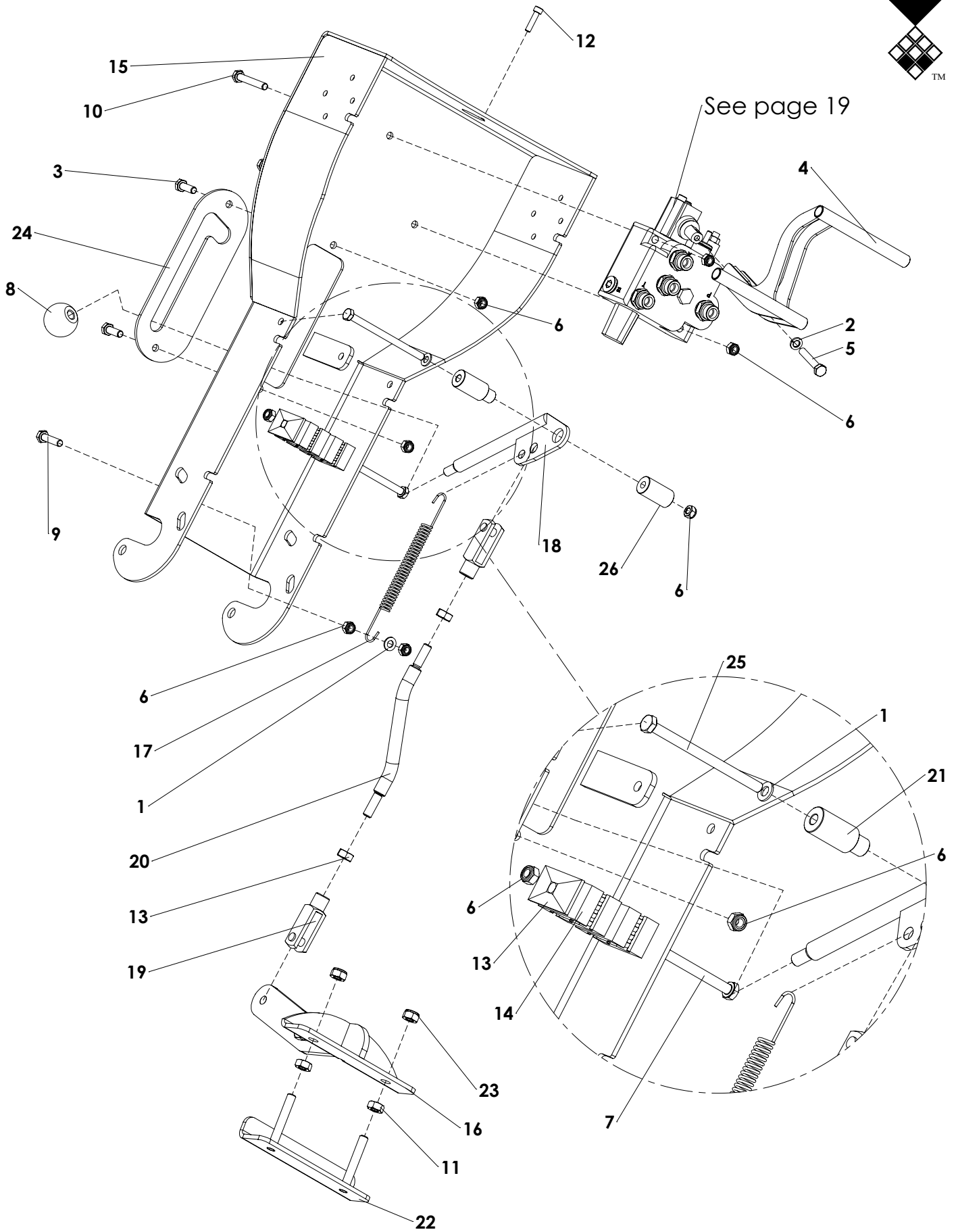

ITEM	PART NUMBER	DESCRIPTION	REMARKS	QUA
1	864.080.030	Washer M8 - ISO 7089		2
2	866.080.020	Spring Washer M8 - DIN 127		1
3	804.080.250	Bolt M8 x 25 - ISO 4017		2
4	470.031.620	Driving handle		1
5	802.080.500	Bolt M8 x 50 - ISO 4014		1
6	830.080.080	Self Lock Nut M8 - ISO 10511		7
7	802.080.750	Bolt M8 x 75 - ISO 4014		1
8	892.100.380	Plastic Ball Knob Din 319 M10		1
9	804.080.350	Bolt M8 x 35 - ISO 4017		1
10	802.080.550	Bolt M8 x 55 - ISO 4014		2
11	826.100.100	Nut M10 - DIN 934		2
12	814.060.250	Bolt M6 x 25 - DIN 912		1
13	547.300.510	Cover plate hose clamp 2x15 - 2x18		2
14	547.150.150	Hose clamp double 15mm		4
15	494.042.066	Console		1
16	470.081.460	Parking brake bracket		1
17	575.021.450	Tension Spring		1
18	470.052.050	Handle		1
19	850.100.720	Fork joint		2
20	416.151.380	Shaft with thread		1
21	404.090.550	Bush		1
22	468.050.180	Bracket		1
23	830.100.100	Self Lock Nut M10 - ISO 10511		2
24	468.042.200	Plate		1
25	802.081.200	Bolt M8 x 120 - ISO 4014		1
26	412.080.410	Shaft		1

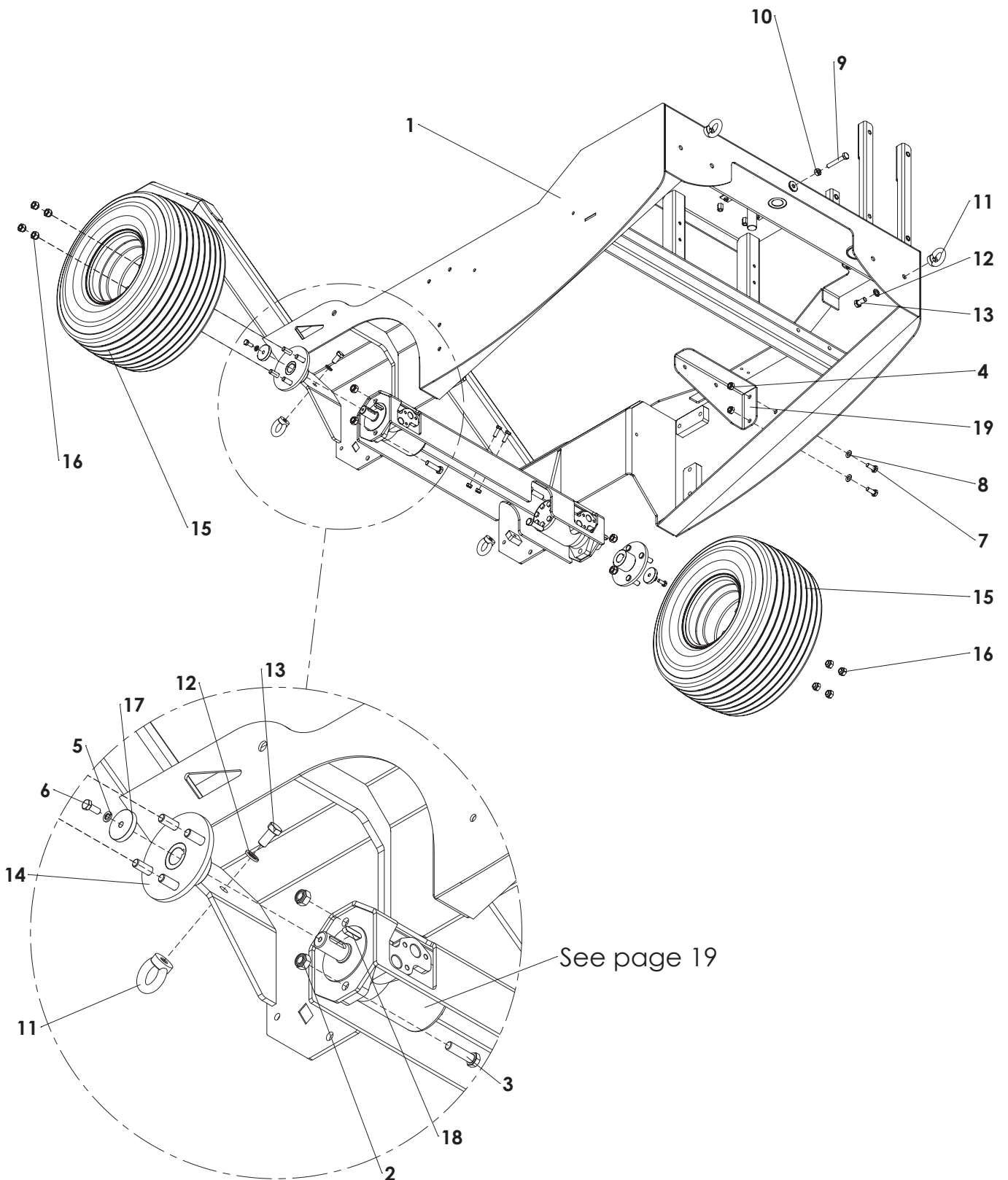

ITEM	PART NUMBER	DESCRIPTION	REMARKS	QUA
1	494.194.099	Frame Core Collector		1
2	830.120.120	Self Lock Nut M12 - ISO 10511		4
3	802.120.450	Bolt M12 x 45 - ISO 4014		4
4	830.100.100	Self Lock Nut M10 - ISO 10511		2
5	866.080.020	Spring Washer M8 - DIN 127		2
6	804.080.200	Bolt M8 x 20 - ISO 4017		2
7	804.100.250	Bolt M10 x 25 - ISO 4017		2
8	864.100.030	Washer M10 - ISO 7089		2
9	804.100.250	Bolt M10 x 65 - ISO 4017		1
10	826.100.100	Nut M10 - DIN 934		1
11	822.120.360	Lifting Eye Nut M12 - DIN 582		4
12	866.120.020	Spring Washer M12 - DIN 127		4
13	804.120.250	Bolt M12 x 25 - ISO 4017		4
14	478.130.088	Wheel hub		2
15	511.542.234	Wheel Complete		2
16	844.120.120	Wheel nut M12x1.5		8
17	406.080.084	Distance bush Ø45/Ø8.2 L=8		2
18	884.080.300	Key 8x7x30 - DIN 6885		2
19	468.042.560	Support		1

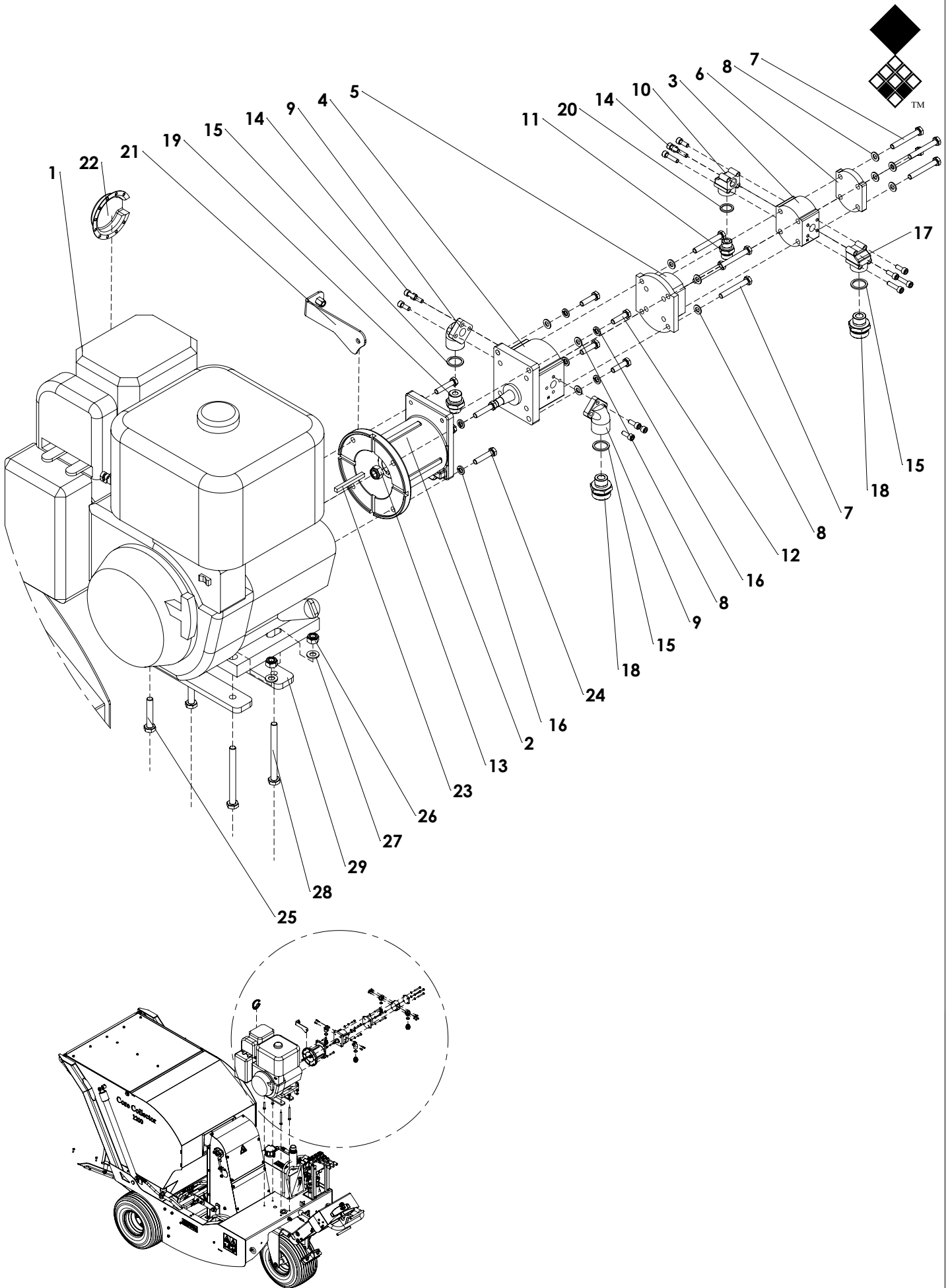

	PART NUMBER	DESCRIPTION	REMARKS	QUA
1	672.250.452	Engine B&S 13hp 1inch axle		1
2	678.251.390	Lantern assemblby 1"		1
3	531.090.690	Hydraulic pump PLP10-2.13 Right		1
4	531.161.260	Hydraulic pump PLP20-8.26 Right		1
5	531.421.020	Adapter PLP20-PLP10		1
6	531.100.740	End plate PLP10		1
7	802.080.604	Bolt M8 x 60 - ISO 4014 Class 12.9		8
8	864.080.030	Washer M8 - ISO 7089		12
9	549.190.320	Press flange 1/2"-14mm		2
10	549.150.290	Press flange 3/8"		1
11	544.170.120	Nipple BSP 3_8" x pipe 12 (M18)		1
12	804.080.300	Bolt M8 x 30 - ISO 4017		4
13	830.120.120	Self Lock Nut M12 - ISO 10511		1
14	814.060.150	Bolt M6 x 16 - DIN 912		14
15	874.210.020	Copper washer 1_2		3
16	866.080.020	Spring Washer M8 - DIN 127		8
17	549.190.290	Press flange 1/2"		1
18	544.210.220	Nipple BSP 1_2" x pipe 22 (M30)		2
19	544.130.402	Nipple BSP 1_2" x pipe 12 (M18)		1
20	874.170.020	Copper washer 3_8		1
21	470.031.420	Cover bracket		1
22	676.026.000	Muffler deflector		1
23	884.060.632	Key 1/4"x1/4"x63		1
24	808.080.380	Bolt 5/16-24 UNF - 1.5"		4
25	802.100.550	Bolt M10 x 55 - ISO 4014		2
26	830.100.100	Self Lock Nut M10 - ISO 10511		4
27	864.100.030	Washer M10 - ISO 7089		4
28	802.101.100	Bolt M10 x 110 - ISO 4014		2
29	464.100.250	Motor strip		2

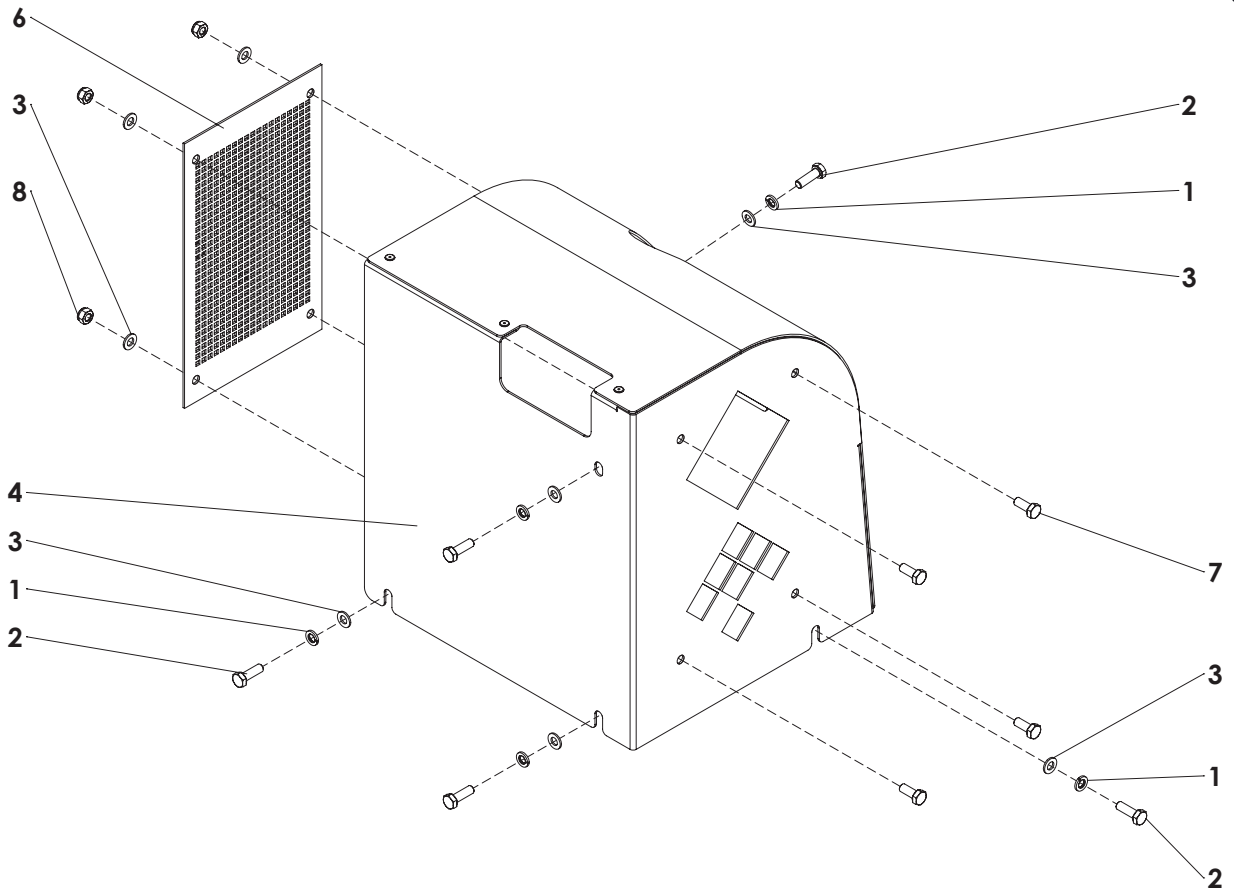

456.023.520

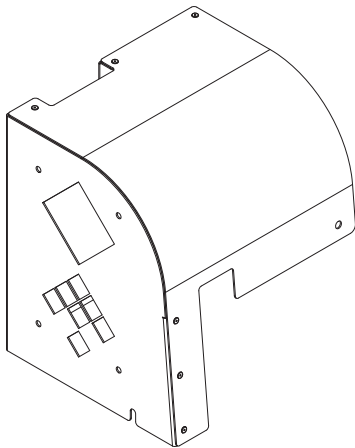

456.023.522

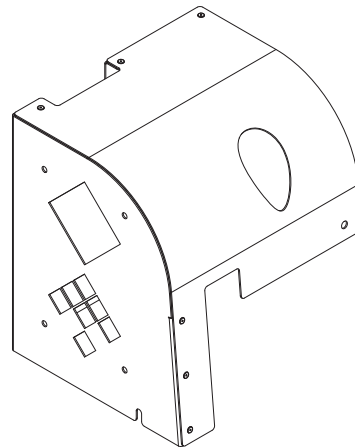

ITEM	PART NUMBER	DESCRIPTION	REMARKS	QUA
1	866.080.020	Spring Washer M8 - DIN 127		5
2	804.080.250	Bolt M8 x 25 - ISO 4017		5
3	864.080.030	Washer M8 - ISO 7089		9
4	456.023.522	Cover	With hole	1
5	456.023.520	Cover	Without hole	1
6	468.023.002	Wire mesh		1
7	804.080.200	Bolt M8 x 20 - ISO 4017		4
8	830.080.080	Self Lock Nut M8 - ISO 10511		4

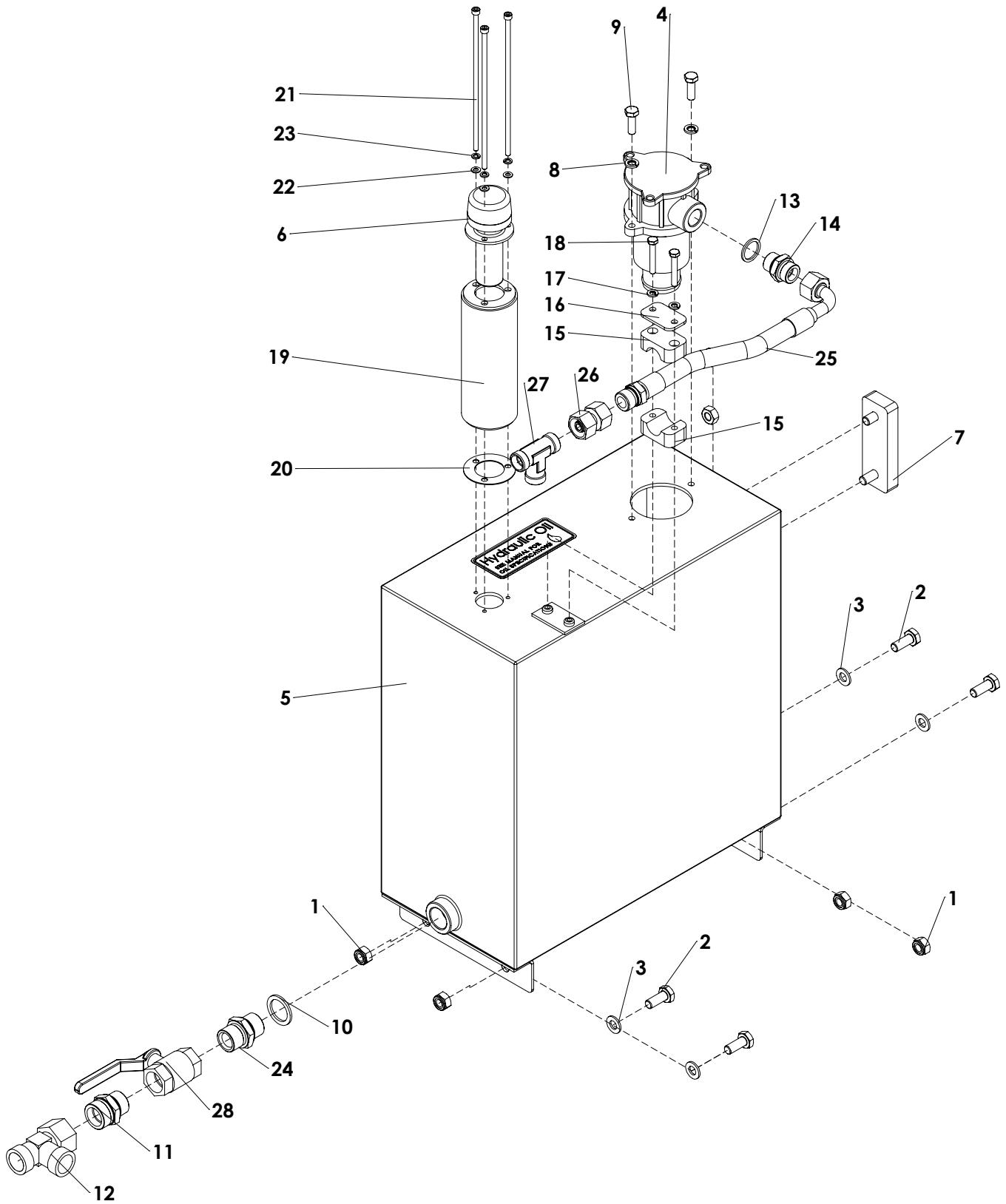

ITEM	PART NUMBER	DESCRIPTION	REMARKS	QUA
1	830.100.100	Self Lock Nut M10 - ISO 10511		4
2	804.100.250	Bolt M10 x 25 - ISO 4017		4
3	864.100.030	Washer M10 - ISO 7089		4
4	533.601.440	Oil filter set		1
5	536.404.245	Oil tank		1
6	533.291.100	Filler cap		1
7	533.381.100	Oil level monitor		1
8	866.080.020	Spring Washer M8 - DIN 127		2
9	804.080.250	Bolt M8 x 25 - ISO 4017		2
10	874.260.020	Copper washer 3/4"		1
11	544.260.300	Nipple BSP 3_4"x pipe 22 (M30)		1
12	544.304.660	T-connector Ø22 x Ø22 Prem. x Ø22		1
13	874.210.020	Copper washer 1_2		1
14	544.210.150	Nipple BSP 1_2" x pipe 15 (M22)		1
15	547.220.302	Pipe clamp single Ø22 Gr3		2
16	549.300.480	Deck plate Gr3		1
17	866.060.020	Spring Washer M6 - DIN 127		2
18	802.060.400	Bolt M6 x 40 - ISO 4014		2
19	478.060.126	Filler pipe		1
20	775.350.560	Seal		1
21	814.051.800	Bolt M5 x 180 - DIN 912 Class 10.9		3
22	864.050.030	Washer M5 - ISO 7089		3
23	866.050.020	Spring Washer M5 - DIN 127		3
24	544.260.260	Nipple BSP 3_4"x 3_4" 60 deg		1
25	541.190.300	Hose NSK13-1/2" TL=300 PGLO132290 + PR1315		1
26	544.155.220	Connector GVO15L15L		1
27	544.154.150	T-Connector 15x15x15		1
28	536.360.550	Ball valve		1

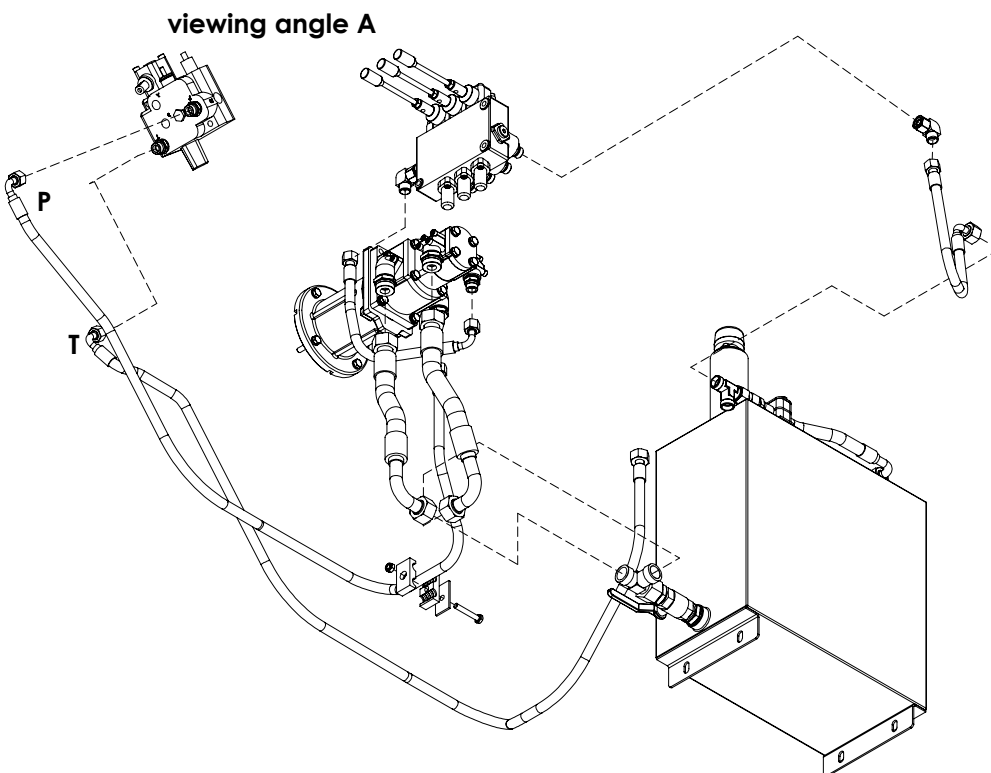
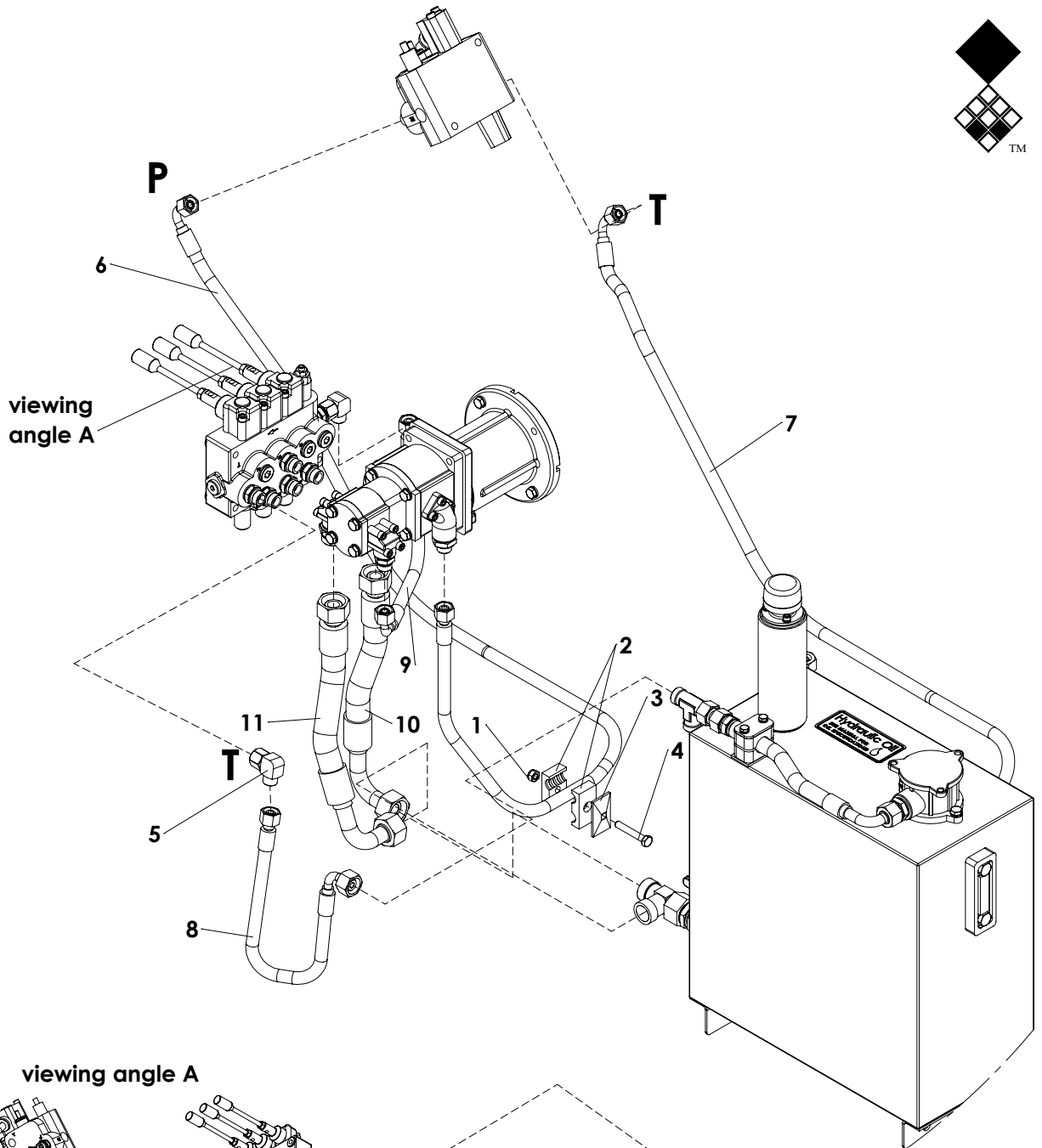

ITEM	PART NUMBER	DESCRIPTION	REMARKS	QUA
1	830.080.080	Self Lock Nut M8 - ISO 10511		1
2	547.150.150	Hose clamp double 15mm		2
3	547.300.510	Cover plate hose clamp 2x15 - 2x18		1
4	802.080.500	Bolt M8 x 50 - ISO 4014		1
5	544.123.180	L-Connector PM. Pipe 12-M18		1
6	541.171.506	Hydraulic hose NSK10 TL=1550 PGLO1018 + PGLO101890		1
7	541.171.508	Hydraulic hose NSK10 TL=1660 PGLO1022 + PGLO101890		1
8	541.170.408	Hydraulic hose NSK10 TL=400 PGLO1018 + PGLO102290		1
9	541.170.350	Hydraulic hose NSK10 TL=350 PGLO1018 + PGLO101890		1
10	541.260.305	Hydraulic hose NST20 TL=305 PGLO 2030 + PGLO 203090		1
11	541.260.305	Hydraulic hose NST20 TL=305 PGLO 2030 + PGLO 203090		1

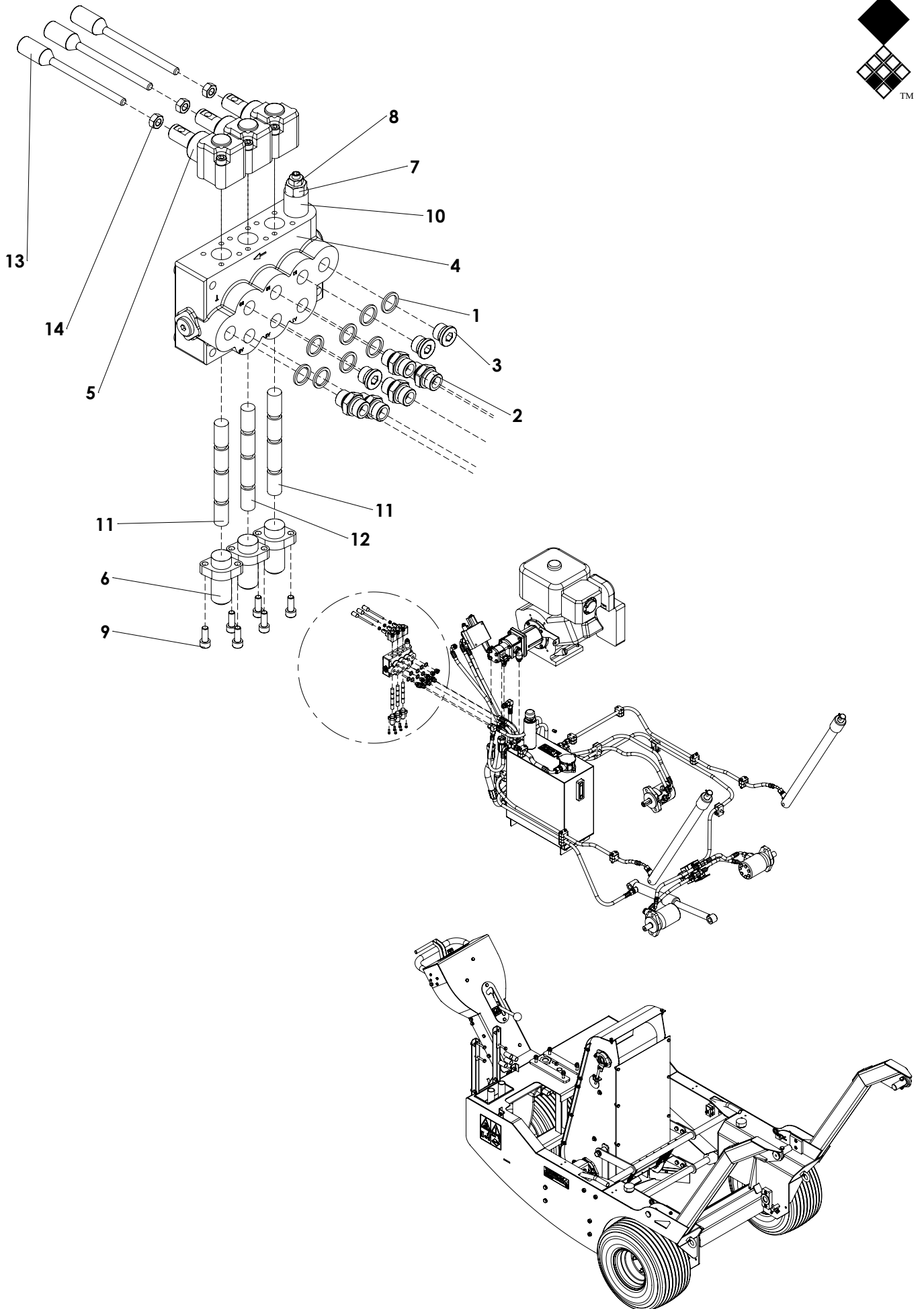
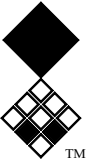

ITEM	PART NUMBER	DESCRIPTION	REMARKS	QUA
1	874.170.020	Copper washer 3_8		8
2	544.170.120	Nipple BSP 3_8" x pipe 12 (M18)		5
3	549.170.160	Blind plug G3/8		3
4	535.691.756	Valve		1
5	536.440.850	Lever base SD5/SD6		3
6	536.280.384	Latching type 10 for Walvoil SD4/SD5		3
7	826.120.120	Nut M12 - DIN 934		1
8	826.080.080	Nut M8 - DIN 934		1
9	814.060.150	Bolt M6 x 16 - DIN 912		6
10	536.140.126	Pressure valve VMPK5		1
11	536.140.124	Plunjer for SD 5		2
12	536.140.122	Plunjer for SD 5		1
13	537.081.200	Handle M8		3
14	826.080.080	Nut M8 - DIN 934		3
	535.691.754	Valve assembly	Items 4-12	1

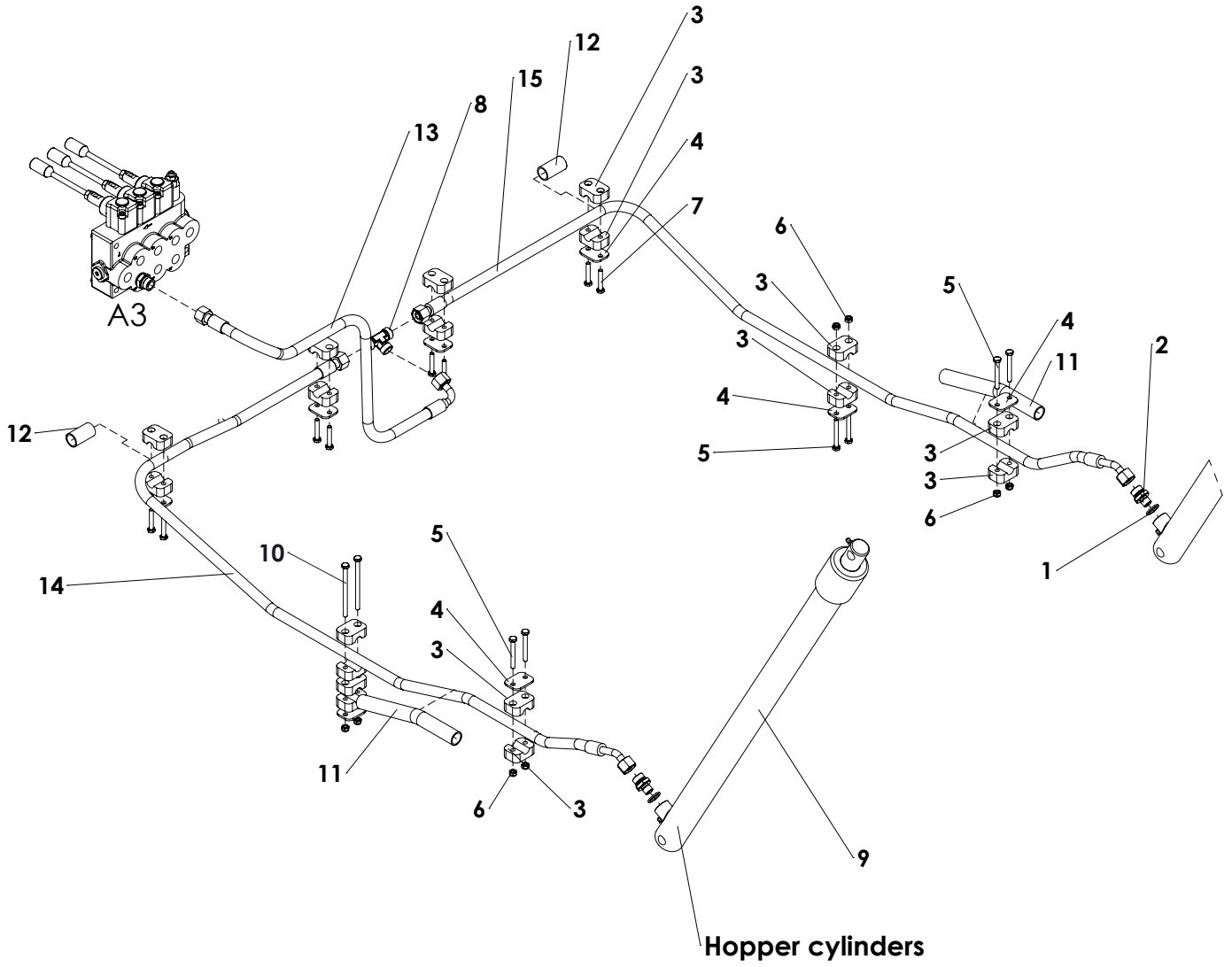

ITEM	PART NUMBER	DESCRIPTION	REMARKS	QUA
1	874.210.020	Copper washer 1_2		2
2	544.130.402	Nipple BSP 1_2" x pipe 12 (M18)		2
3	547.150.300	Pipe clamp single Ø15 Gr2		18
4	549.300.400	Deck plate Gr2		8
5	802.060.500	Bolt M6 x 50 - ISO 4014		6
6	830.060.060	Self Lock Nut M6 - ISO 10511		8
7	802.060.350	Bolt M6 x 35 - ISO 4014		8
8	544.124.125	T-Connector 12x12x12		1
9	534.308.040	Single acting cylinder Ø30-60 Stroke=700mm		2
10	802.060.900	Bolt M6 x 90 - ISO 4014		2
11	549.012.500	Hose protection L=250		2
12	549.015.000	Hose protection L=500		2
13	541.170.650	Hydraulic hose NSK10 TL=650 PGLO1018 + PGLO101890		1
14	541.171.504	Hydraulic hose NSK10 TL=1550 PGLO1018 + PGLO101845		1
15	541.171.504	Hydraulic hose NSK10 TL=1550 PGLO1018 + PGLO101845		1

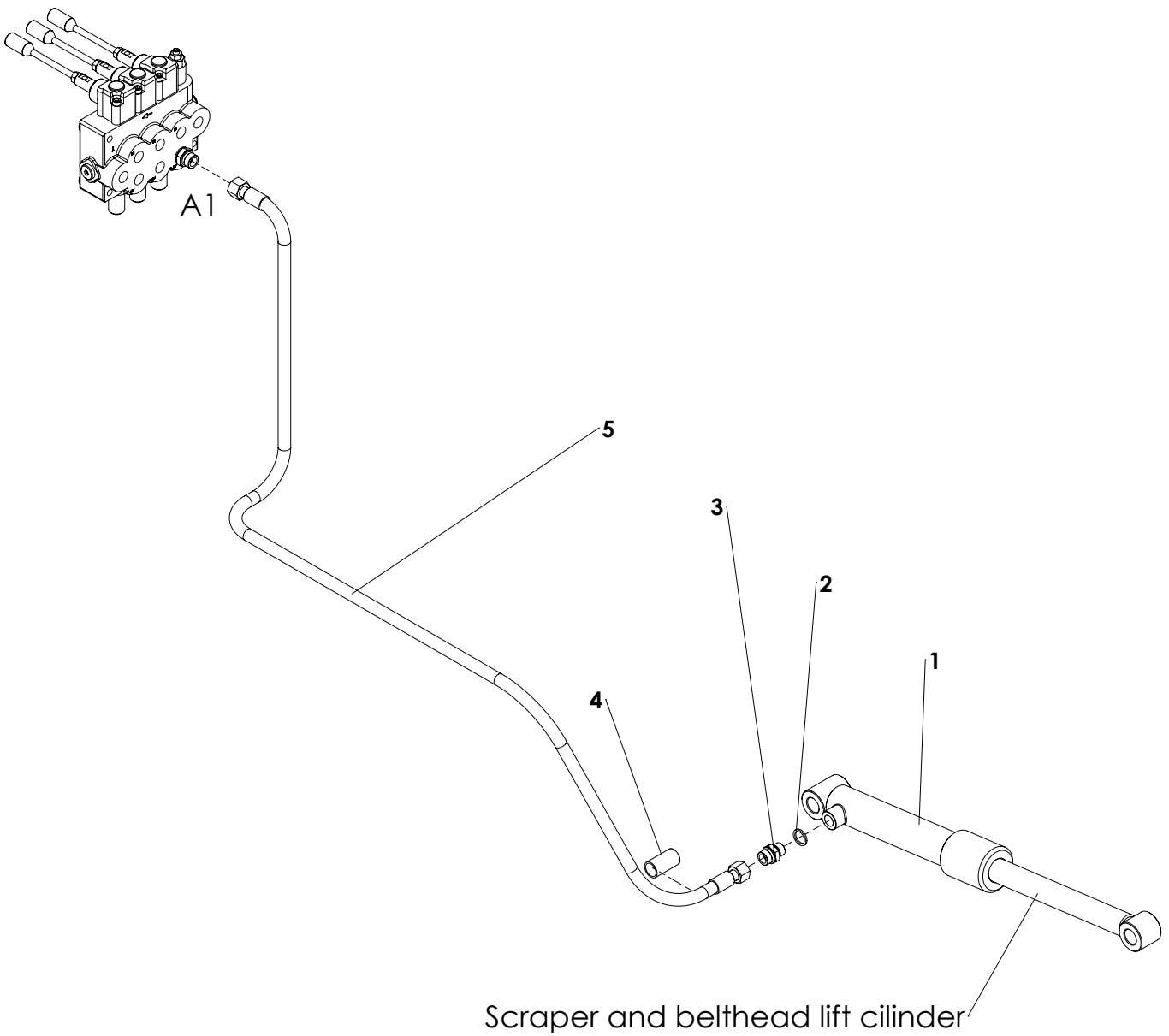

	PART NUMBER	DESCRIPTION	REMARKS	QUA
1	534.303.560	Hydraulic cylinder 30/45 Stroke=200		1
2	874.170.020	Copper washer 3_8		1
3	544.170.120	Nipple BSP 3_8" x pipe 12 (M18)		1
4	549.015.000	Hose protection L=500		1
5	541.171.750	Hydraulic hose NSK10 TL=1750 PGLO1018 + PGLO101890		1

ITEM	PART NUMBER	DESCRIPTION	REMARKS	QUA
1	830.080.080	Self Lock Nut M8 - ISO 10511		2
2	532.251.872	Hydraulic motor OMP 32		1
3	874.210.020	Copper washer 1_2		2
4	544.130.402	Nipple BSP 1_2" x pipe 12 (M18)		2
5	547.150.150	Hose clamp double 15mm		4
6	547.300.510	Cover plate hose clamp 2x15 - 2x18		2
7	802.080.500	Bolt M8 x 50 - ISO 4014		2
8	541.171.506	Hydraulic hose NSK10 TL=1550 PGLO1018 + PGLO101890		1
9	541.171.506	Hydraulic hose NSK10 TL=1550 PGLO1018 + PGLO101890		1

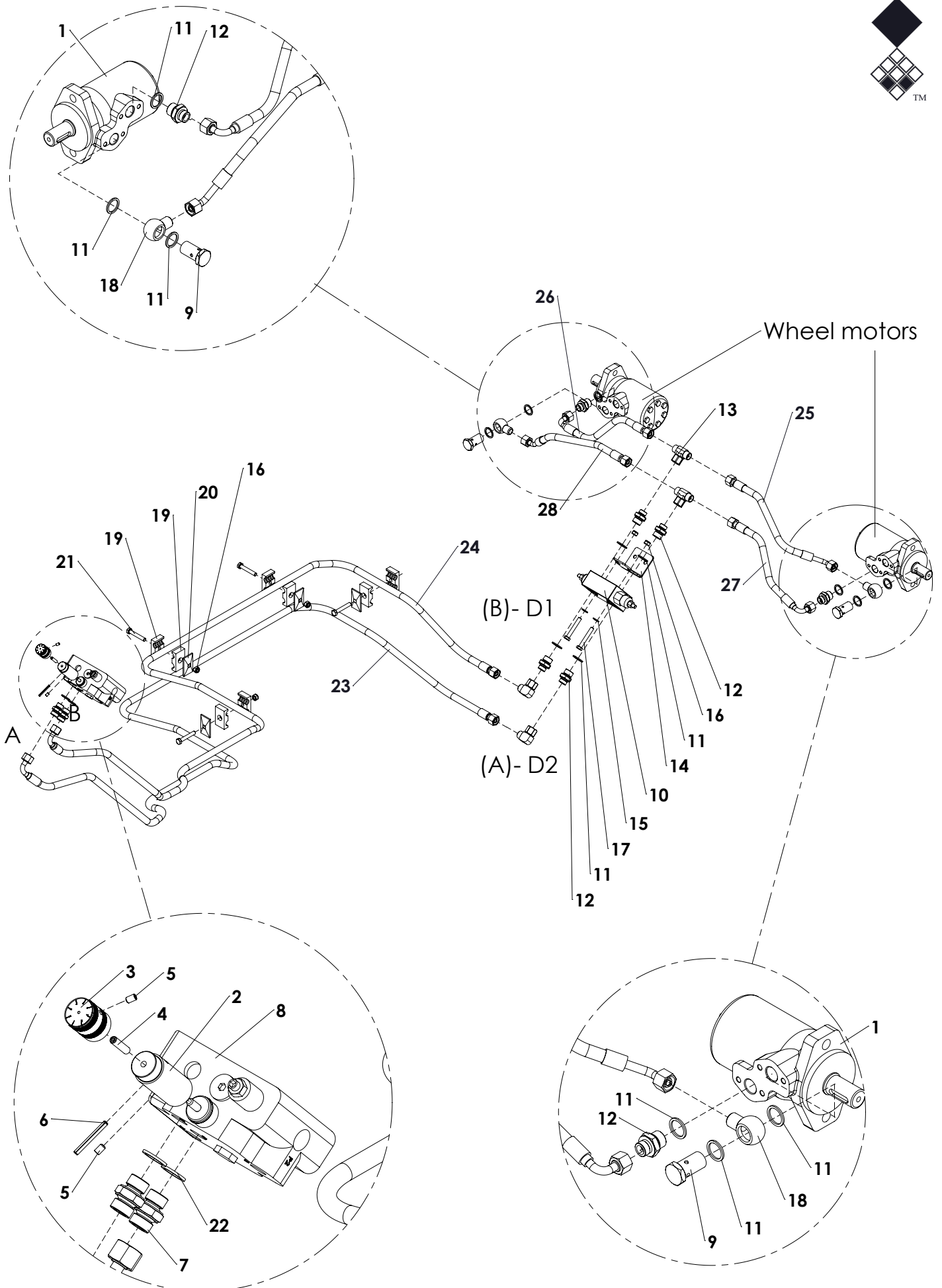

ITEM	PART NUMBER	DESCRIPTION	REMARKS	QUA
1	532.251.600	Hydraulic motor OMP 250		2
2	472.260.600	Knob extension		1
3	537.260.320	Adjustment Knob		1
4	818.060.250	Set screw M6 x 25 - DIN 913		1
5	818.050.080	Set screw M5 x 8 - DIN 913		2
6	878.040.350	Roll Pin 4 x 35 - ISO 8752		1
7	544.170.120	Nipple BSP 3_8" x pipe 12 (M18)		2
8	535.631.750	Valve assembly		1
9	544.202.450	Cavity Bolt 1/2"		2
10	536.402.100	Dual cross line relief valve		1
11	874.210.020	Copper washer 1_2		10
12	544.130.402	Nipple BSP 1_2" x pipe 12 (M18)		6
13	544.124.126	T_-Connector PM, Pipe 12-M18		2
14	468.030.902	Valve bracket		1
15	864.080.030	Washer M8 - ISO 7089		2
16	830.080.080	Self Lock Nut M8 - ISO 10511		6
17	802.080.550	Bolt M8 x 55 - ISO 4014		2
18	549.210.340	Nipple DBBM 1/2" BSP - 12L (M18)		2
19	547.150.150	Hose clamp double 15mm		8
20	547.300.510	Cover plate hose clamp 2x15 - 2x18		4
21	802.080.500	Bolt M8 x 50 - ISO 4014		4
22	874.170.020	Copper washer 3_8		2
23	541.172.950	Hydraulic hose NSK10 TL=2950 PGLO1018 + PGLO101890		1
24	541.172.950	Hydraulic hose NSK10 TL=2950 PGLO1018 + PGLO101890		1
25	541.170.406	Hydraulic hose NSK10 TL=400 PGLO1018 + PGLO101845		1
26	541.170.404	Hydraulic hose NSK10 TL=400 PGLO1018 + PGLO101890		1
27	541.170.404	Hydraulic hose NSK10 TL=400 PGLO1018 + PGLO101890		1
28	541.170.406	Hydraulic hose NSK10 TL=400 PGLO1018 + PGLO101845		1



Hydraulic assembly schematic lift section

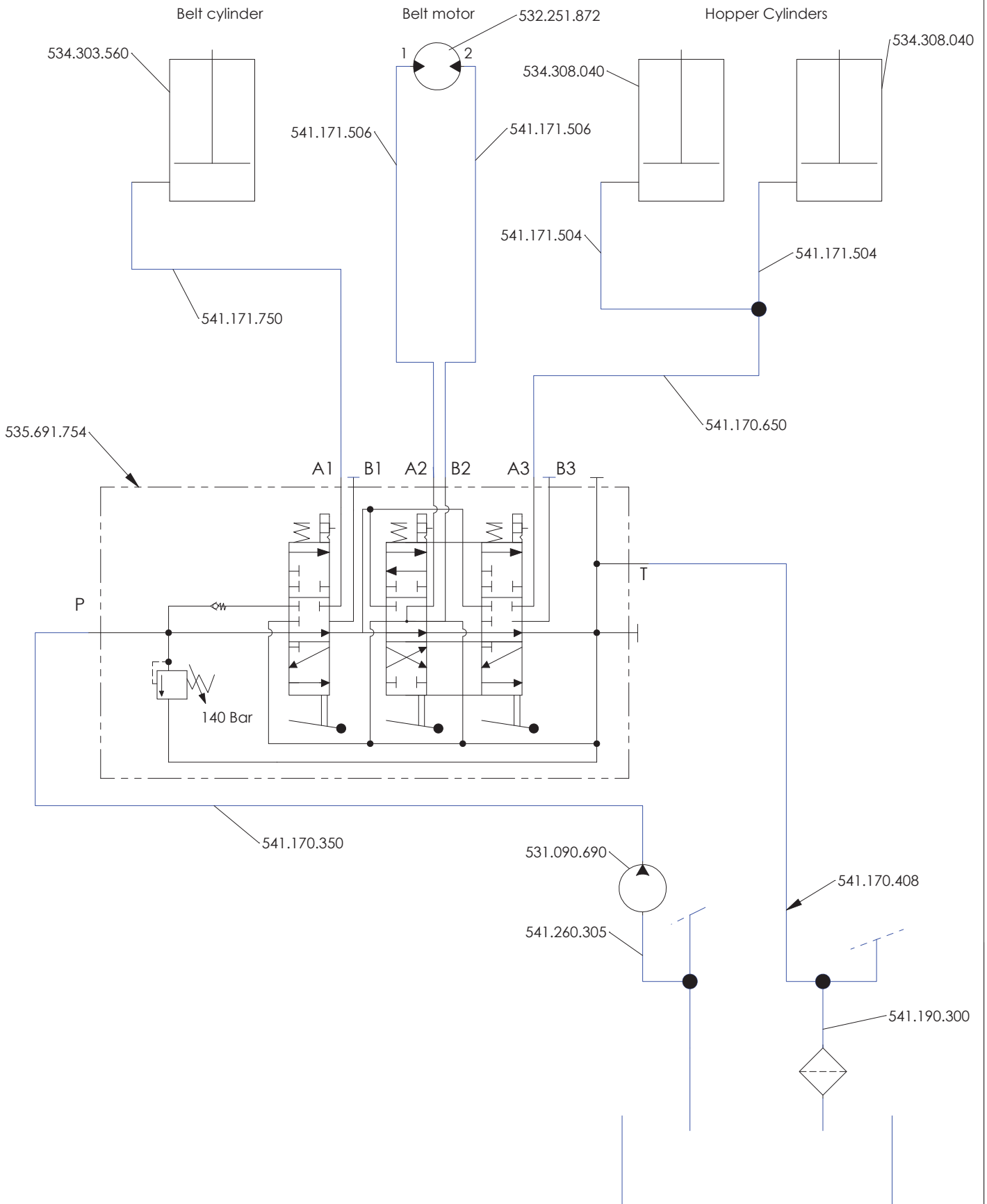



Hydraulic assembly schematic drive section

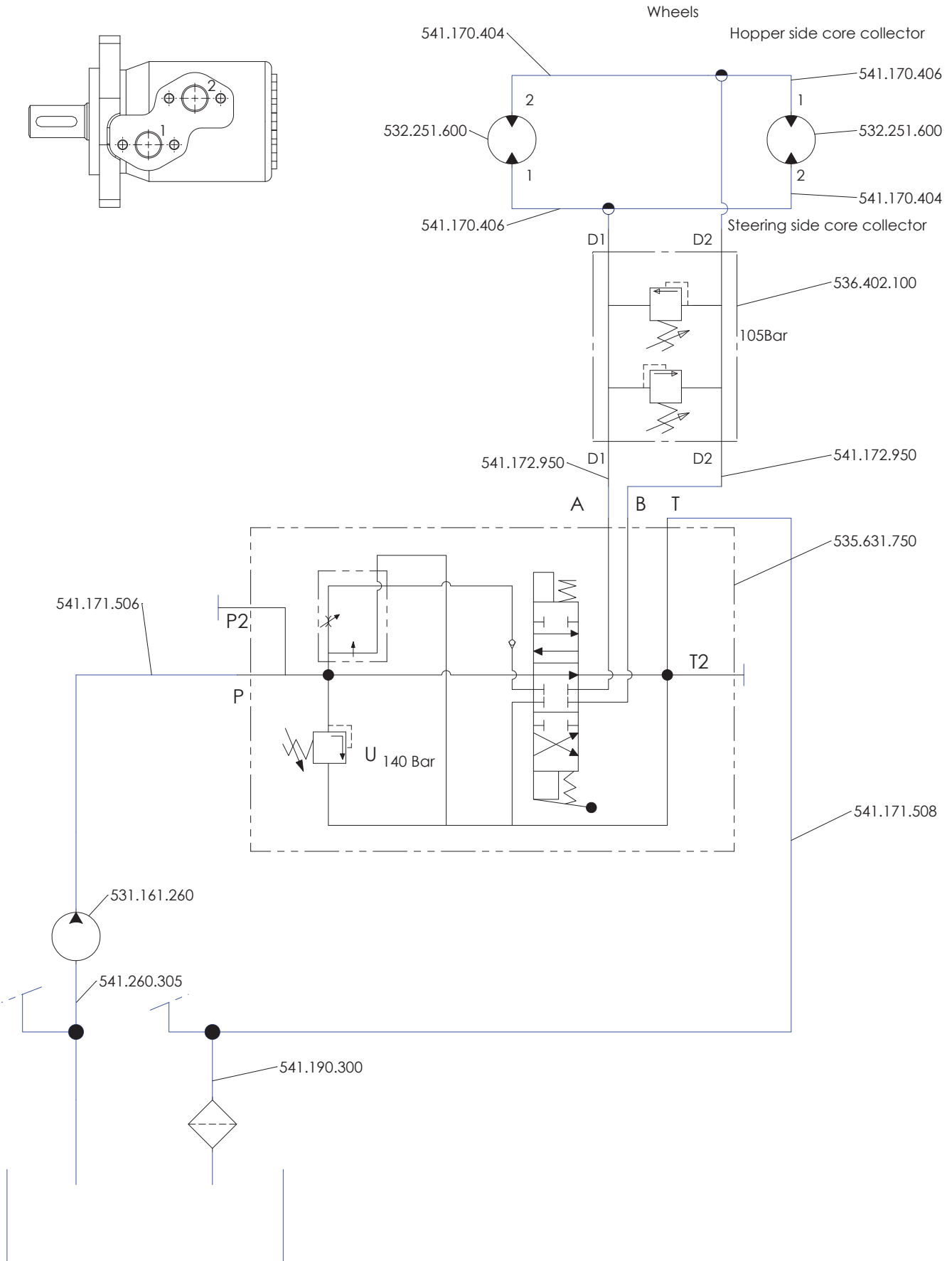

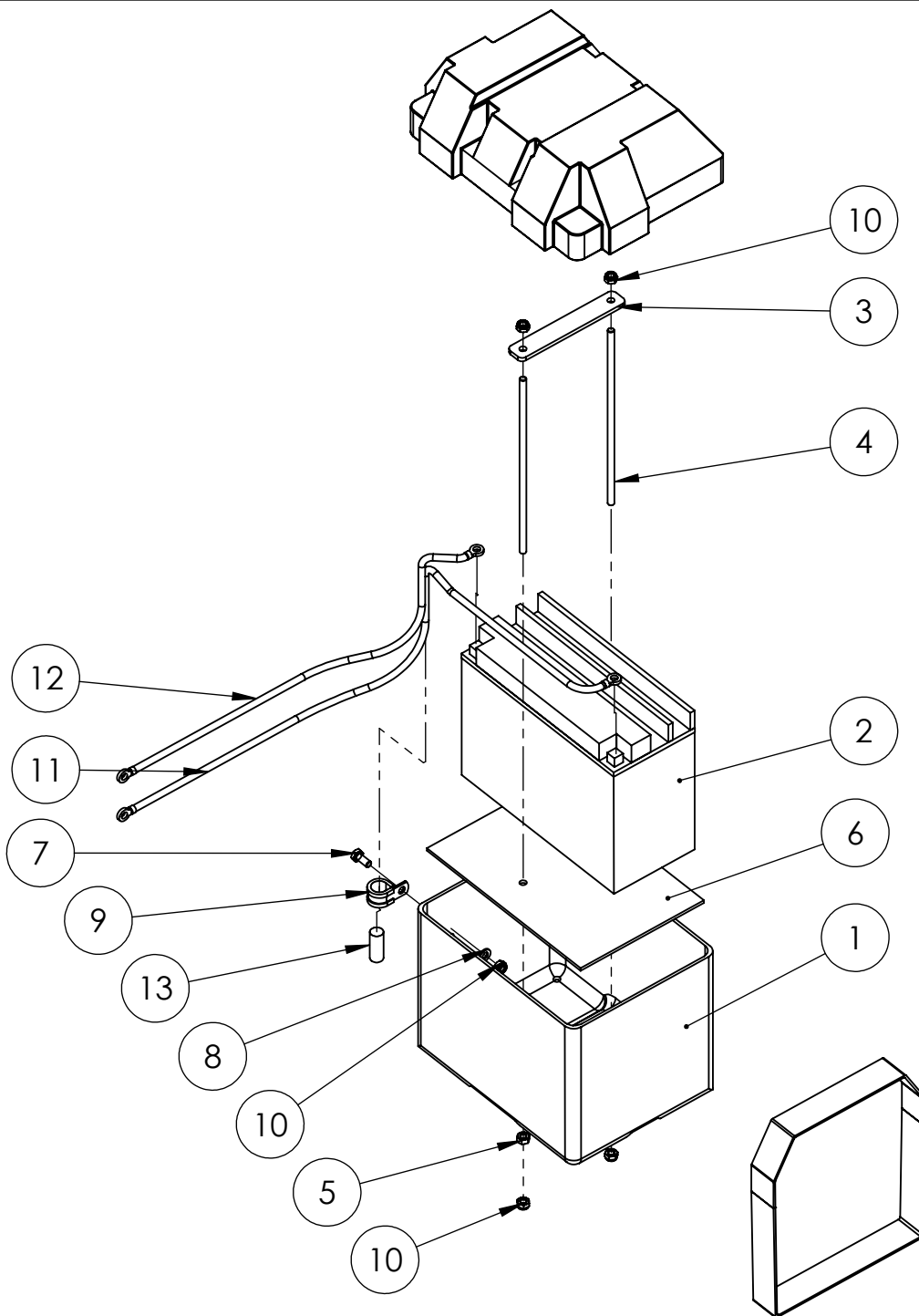

ITEM	PART NUMBER	DESCRIPTION	REMARKS	QUA
1	569.180.270	Battery box set		1
2	562.912.060	Battery 12V 20Ah 200A		1
3	464.041.204	Strip		1
4	852.062.000	Threaded rod M6, class 8.8		2
5	826.060.060	Nut M6 - DIN 934		2
6	446.032.080	Rubber flap		1
7	804.060.140	Bolt M6 x 14 - ISO 4017		1
8	864.060.030	Washer M6 - ISO 7089		1
9	547.130.300	Hose clamp 15		1
10	830.060.060	Self Lock Nut M6 - ISO 10511		5
11	563.100.700	Electric cable KA11004 10mm ² TL=700+2x8KW177784202		1
12	563.100.702	Electric cable KA11005 10mm ² TL=700+2x8KW177784202		1
13	549.122.800	Hose protection L=280		1